

# PLUG-IN-MODULES

Plug-in-Modules introduced with the Series 20 Card Frames offer improved mechanical rigidity, precision and internal working space.

These fully enclosed all-aluminium modules offer a high degree of protection against EMI / RFI emissions from adjacent circuitry.

PIM's are available in heights of 3U & 6U to suit single height and double height Euro Card Frames.

The modules have an internal groove for locating standard Euro PCB's of 160, 220 or 280mm depth. Euro Connectors fixed to the PCB project through the slots provided in the Rear Plates. The PIMs slide into the Card Frame along the standard card guides and lock perfectly with the Backplane Connectors fixed at the rear of the card frame.



*Series 20 Card Frames with Plug-in-Modules*

## Features

- All aluminium construction
- Proprietary extrusions for width and depth
- Internal groove for locating of PCBs
- Maximization of space for circuit components
- Width profile for increased rigidity

## Sizes

Heights: 3U & 6U  
Widths : 10T, 14T, 21T & 28T  
Depths : 160, 220 & 280mm

## Material and Finish

- All aluminium construction, frame made of extrusions, front panel of 2.5mm thick aluminium.
- Top, Bottom and Side Covers of 0.9mm and Rear panel of 2mm thick aluminium sheet.
- All aluminium parts have natural alodine finish.

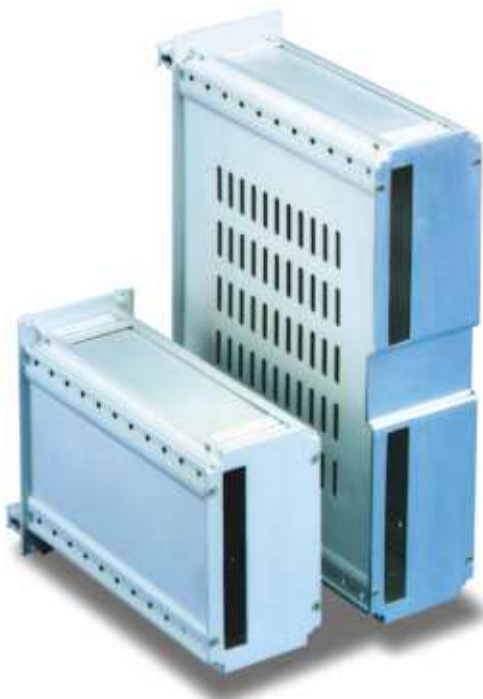

*Rear view of Modules*

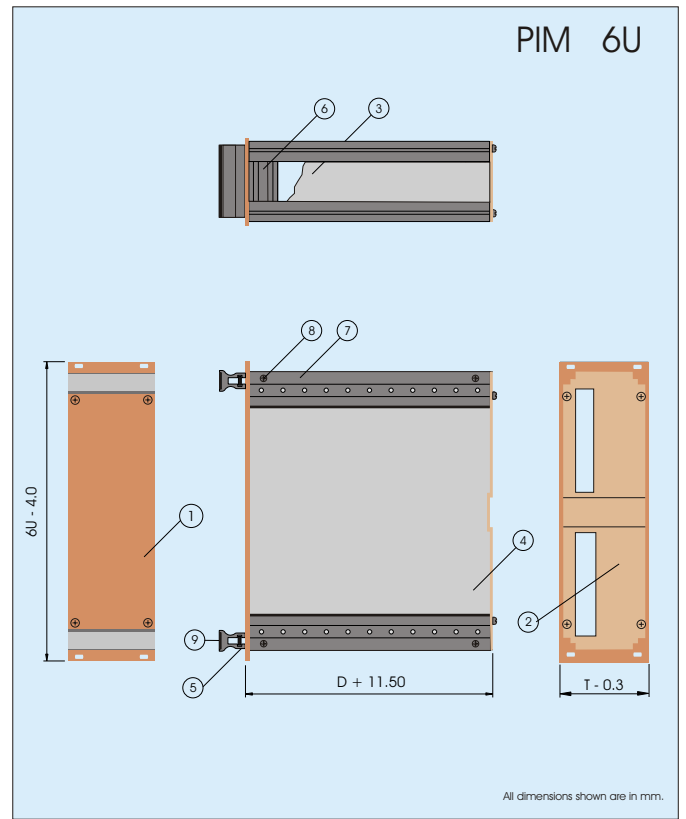
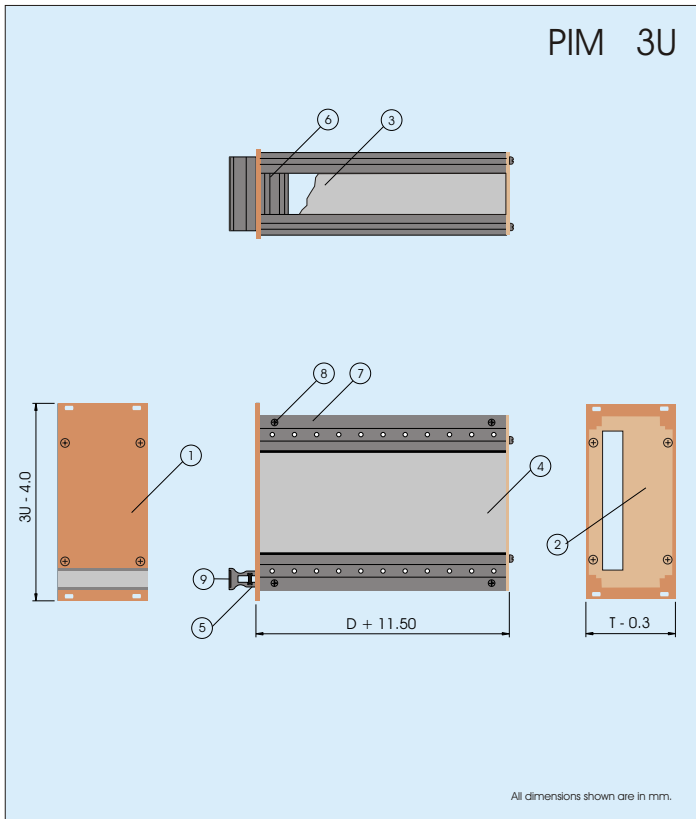

### Ordering Information

Height	Width	Depth		
		160mm	220mm	280mm
3U	10T	29-8312-X	29-8322-X	29-8332-X
	14T	29-8313-X	29-8323-X	29-8333-X
	21T	29-8314-X	29-8324-X	29-8334-X
6U	28T	29-8315-X	29-8325-X	29-8335-X
	10T	29-8612-X	29-8622-X	29-8632-X
	14T	29-8613-X	29-8623-X	29-8633-X
6U	21T	29-8614-X	29-8624-X	29-8634-X
	28T	29-8615-X	29-8625-X	29-8635-X

### Scope of Supply

No.	Description	Qty
1	Front Panel	1
2	Rear Panel	1
3	Cover Top/ Bottom	2
4	Cover Side	2
5	Profile Facia Handle	1
6	Profile PIM Width	4
7	Profile PIM Depth	4
8	Hardware Set	1
9	Decorative Strip for Facia Handle	1

IF PIM Rear Panel is required with a slot for connectors, mention specifically in PO. If Front Panels are to be customized with cut-outs, holes, printing etc, refer to APSL for specific offer.

Slots for ventilation are normally provided on the two side panels only, but can be provided on Top & Bottom panels for 14, 21 and 28T wide PIMs. For specifying slotting details use the suffix 'X' as indicated below.

- X = 0 No Slotting, all covers plain
- X = 1 Side Covers with ventilation slots
- X = 2 Top and Bottom covers with ventilation slots
- X = 3 Top, Bottom and Side covers with ventilation slots



Front view of Modules