

# SERIES 20

## CARD FRAMES



Some of the different styles of Card Frames available in the Series 20 range

The Series 20 family of Card Frames from APW President has several new features that enhance the level of precision and adaptability. The side panels have half-shears and locating holes at 15mm depth intervals for accurate positioning of the width extrusions. This design not only increases precision, but also provides considerable flexibility to the user. Additional clearance is provided between the side panels and the solder-side of the first PCB. Front and rear extrusions are printed with location numbers.

Card Frames are normally supplied in kit-form. Assembly is simple, requiring only a screw-driver.

Card Frames form the basic building blocks of instrumentation system. Most application requirements can be met with the choice of heights, widths and depths. Customized solutions can be developed to fulfil specific customer needs.



Widths from 21T to 84T

### Features

- Rapid assembly and easy accessibility
- Side Panels are provided with "Half Shears"
- Top and bottom covers - plain or with ventilation slots.
- Front & Rear panels - Screw-on type or hinged to open either downwards or sideways
- The hinge arrangement allows the panel to open 180 degree and remain clear of the adjacent profile
- Full range of accessories for direct mounting of Connectors and backplanes - or a combination of both

### Sizes

Heights : 2U, 3U, 4U, 5U & 6U  
Widths : 21T, 42T, 63T, 81T & 84T  
Depths : 180, 240, 300 & 360mm



Heights from 2U to 6U & beyond

### Material and Finish

- Side Panels are of 14 SWG ( 2.0mm ) aluminium. The two front profiles ( 82-42XX ) have a 3.00mm extension. Rear profiles ( 82-44XX ) are suitable for direct mounting of Motherboards without necessity of Insulation Spacers
- Front & Rear Panels are made of 2.5mm thick aluminium sheets
- Top and Bottom Covers can be supplied with a natural anodised finish or powder coated

## Optional Accessories

- Threaded Strips
- Card Guides
- Front & Rear Panels
- Top & Bottom Covers
- Pull Out Handles
- Facia Panels
- Plug-in-Modules
- Connector Mounting Sets
- Plastic Accessories

## Scope of Supply

No.	Description	Qty
1	Front Profile	2
2	Profile, S20 Mothrbd Mtg.	2
3	Profile, S20 Side Angle	2
4	Panel, Side S20	2
5	Hardware set for Assly	1



*Card guides & Threaded strips shown are not included in standard scope of supply.*

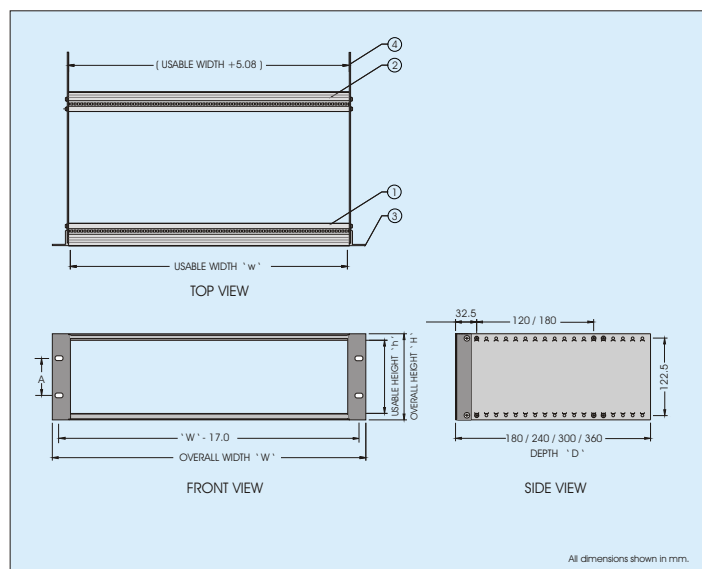

## Dimensions

U	Height		Width		
	Overall H	Usable h	T	Overall W	Usable w
2U	88.00	68.00	21T	162.56	106.68
3U	132.50	112.50	42T	269.24	213.36
4U	177.00	157.00	63T	375.92	320.04
5U	221.50	201.50	81T	482.60	411.48
6U	266.00	246.00	84T	482.60	426.72

19" Mounting	
U	A
2U	76.20
3U	57.10
4U	101.60
5U	146.10
6U	190.60

## Ordering Information

Height	Width	Depth in mm			
		180mm	240mm	300mm	360mm
2U	21T	20-2210	20-2220	20-2230	20-2240
	42T	20-4210	20-4220	20-4230	20-4240
	63T	20-5210	20-5220	20-5230	20-5240
	81T	-	20-6220	20-6230	20-6240
	84T	20-7210	20-7220	20-7230	20-7240
3U	21T	20-2310	20-2320	20-2330	20-2340
	42T	20-4310	20-4320	20-4330	20-4340
	63T	20-5310	20-5320	20-5330	20-5340
	81T	-	20-6320	20-6330	20-6340
	84T	20-7310	20-7320	20-7330	20-7340
4U	21T	20-2410	20-2420	20-2430	20-2440
	42T	20-4410	20-4420	20-4430	20-4440
	63T	20-5410	20-5420	20-5430	20-5440
	81T	-	20-6420	20-6430	20-6440
	84T	20-7410	20-7420	20-7430	20-7440
5U	21T	20-2510	20-2520	20-2530	20-2540
	42T	20-4510	20-4520	20-4530	20-4540
	63T	20-5510	20-5520	20-5530	20-5540
	81T	-	20-6520	20-6530	20-6540
	84T	20-7510	20-7520	20-7530	20-7540
6U	21T	20-2610	20-2620	20-2630	20-2640
	42T	20-4610	20-4620	20-4630	20-4640
	63T	20-5610	20-5620	20-5630	20-5640
	81T	-	20-6620	20-6630	20-6640
	84T	20-7610	20-7620	20-7630	20-7640



Rear View